



CAMBIA IL TUO SPAZIO

DISEGNA LO STILE
DI CASA TUA



rivenditore



ITALIAN DOORS STORY

www.gd-dorigo.com

LE PORTE MADE IN ITALY ELEGANTI E INNOVATIVE, CHE APRONO I NUOVI SCENARI DELL'ARCHITETTURA D'INTERNI.

Un repertorio completo di porte per edifici privati e pubblici, dedicato a chi cerca contenuti estetici di prestigio e qualità superiore. Lo firma GD Dorigo, l'industria italiana che gestisce l'alta tecnologia con la cura tipica della tradizione artigianale.



GD DORIGO rappresenta una delle principali realtà industriali italiane che ha saputo evolvere l'eccellente maestria artigiana in processi d'industrializzazione avanzati, nell'ambito della produzione di porte d'arredo per interni e di porte tecnologiche per il comparto dell'edilizia professionale come ospedali, alberghi, scuole e uffici.

Il cuore pulsante dell'Impresa è evidenziato da quei valori tipici dell'imprenditoria italiana che hanno poggiato la crescita e lo sviluppo, centrando la propria attenzione sulle persone quale leva fondamentale per affrontare con professionalità l'evoluzione continua dei mercati.

Il brand raffigura così un'azienda al passo con i tempi e una organizzazione fondata sulla razionalità del sistema produttivo e sull'esperienza continuamente alimentata dagli stimoli dell'innovazione. In linea con le più accentuate tendenze del mercato, oggi GD DORIGO esprime anche una forte cultura "green" nella scelta delle materie prime e delle soluzioni energetiche alternative, finalizzate a contenere l'impatto e l'inquinamento industriale. Ogni metro quadro dell'Impresa racconta le scelte imprenditoriali e il percorso evolutivo per certificare un prodotto di elevato livello funzionale ed estetico. Particolare attenzione strategica è continuamente data al Design per capitalizzare quella cultura manifatturiera che come in un "laboratorio del made in Italy" dà forma alle nuove idee e stimola sperimentazioni costruttive che si trasformano in porte di successo; come quelle sviluppate con il contributo creativo d'importanti designers come GIUGIARO.

La porta è il fulcro GD DORIGO più importante, su cui ogni risorsa pone le sue competenze e le sue attenzioni con una creatività consapevole che comunica e rappresenta tutto il valore del brand. Valore che accompagna il prodotto anche in tutti quei servizi commerciali e di assistenza tecnica al cliente che trovano nella cordialità del rapporto con l'Azienda un riferimento esclusivo per operare con sicurezza e soddisfazione.

Automazione industriale e sapienza artigiana firmano ogni prodotto che partendo da Pieve di Soligo si espande progressivamente non solo nel nostro paese ma in tutte quelle aree emergenti del mondo che ambiscono ad assorbire la nostra cultura e i valori dell'estetica e dell'immagine raccontata attraverso le nostre porte. Ecco perché oggi, sulla base della nostra esperienza ci pregiamo di invitare i nostri migliori clienti ad aprire con noi la porta del futuro. Insieme ancora una volta per condividere, come nel passato, un'esperienza unica nel suo genere.





www-gd-dorigo.com



Technology research
and design



INDEX COLLECTION

LUCE & PRATIKA	Pag.	04
ETEREA	Pag.	10
IKI GIUGIARO DESIGN	Pag.	12
ART RAIMONDO SANDRI DESIGN	Pag.	14
ZEN RAIMONDO SANDRI DESIGN	Pag.	15
DEGÒ	Pag.	16
KING	Pag.	18
DECOR	Pag.	20
IMAGO	Pag.	22
LEGO	Pag.	26
EFFIGIES	Pag.	28
VENUS	Pag.	30
Sliding Doors	Pag.	34
Essenze/Laccati/Stipiti Wood Veneers/Lacquered /Door Post	Pag.	36
Vetri/Glasses	Pag.	38
Finiture/Stipiti Finishing/Door Post	Pag.	40
PEGASO	Pag.	42
MEDUSA	Pag.	46
ZEUS	Pag.	48
VENERE	Pag.	50
ATLANTE	Pag.	52



SET 6 - ART. 800 - Alluminio Argento Opaco - Vetro 59
Silver matt Aluminum - Glass 59

4

SET 3 - ART. 830-800 - Alluminio Argento Opaco - Vetri 57-58
Silver matt Aluminum - Glasses 57-58





SET 4 - ART. 800 - 822 V79 - Alluminio Argento Opaco - Rovere Tabacco - Vetro 79
Silver matt Aluminum - Tabacco Oak - Glass 79

5

SET 3 - ART.830 - Alluminio Argento Opaco - Vetro 80
Silver matt Aluminum - Glass 80





LUCE & PRATIKA
Collection



SET 1 - ART. 800 - Alluminio Argento Opaco - Vetro 80
Silver matt Aluminum - Glass 80

6

SET 6 - ART. 800 - Alluminio Argento Lucido - Frassino Natural Poro Bianco - Sistema modulare per attrezzare le pareti
Silver shiny Aluminum - White Ash-Tree Natural Poro - Modular system to equip and decorate the walls





SET 3 - ART. 810 - Alluminio Argento Opaco - Rovere Lavagna - Sistema modulare per attrezzare le pareti
Silver matt Aluminum - Lavagna Oak - Modular system to equip and decorate the walls





SET 1 - ART. 800/103 - 800/105 - Alluminio Argento Opaco - Stampa digitale su fondo bianco - Sistema modulare per attrezzare le pareti
Silver matt Aluminum - Digital printing on white base - Modular system to equip and decorate the walls

8

SET 1 - ART. 800 - Alluminio Argento Lucido - Rovere Corda - Sistema modulare per attrezzare le pareti
Silver shiny Aluminum - Corda Oak - Modular system to equip and decorate the walls



PRATIKA

MODULI E COMPONENTI

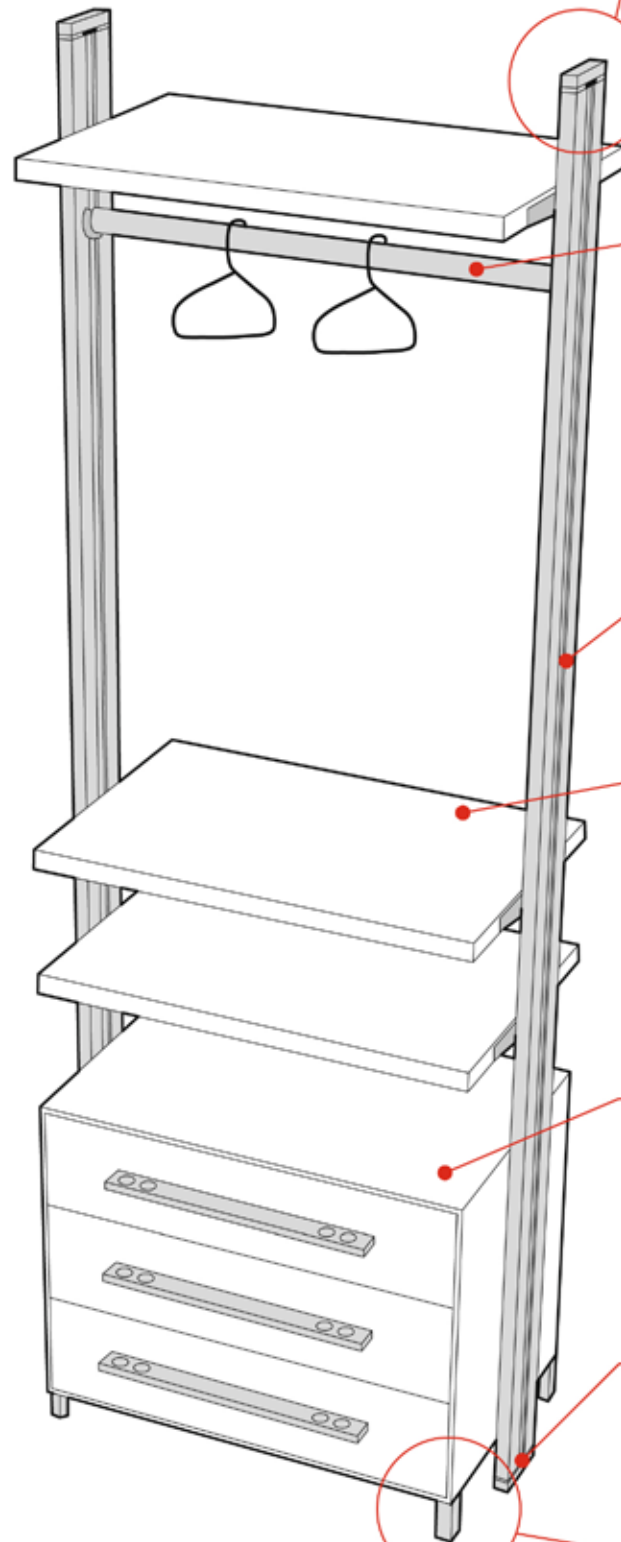

PIEDINO superiore in alluminio pressofuso con vite di regolazione da 0 mm. a 20 mm. per il fissaggio a soffitto.

UPPER FOOT made of die-cast aluminium with adjusting screw from 0 to 20 mm. for fixing the upright to the ceiling.



Adattatore per soffitti inclinati da 0° a 45°

Upright adaptor for sloping ceilings 0°/45°

ACCESSORI:

TUBO appendiabiti in alluminio anodizzato, fornito con reggitubo.

ASTA appendiabiti (servetto) in alluminio.

ACCESSOIRES:

CLOTHES RAIL in anodized aluminium, comes with pair of clothes rail holder.

PULL-OUT CLOTHES RAIL in anodized aluminium.

MONTANTE verticale portante in alluminio estruso.

UPRIGHT made of extruded anodized aluminium.

PIANI in PVC Bianco, Magnolia o Perla, sp. 28,5 mm, completi di 2 reggipiani, disponibili in 3 profondità: 330, 458 o 586 mm. Larghezza massima 1300 mm.

TOPS White, Magnolia or Pearl PVC finishing, thickness 28,5 mm., 2 shelf support included, available in 3 dimensions: 330, 458 and 586 mm. Maximum width 1300 mm.

CASSETTIERE in PVC Bianco, Magnolia o Perla, prof. 427 e 550 mm., disponibili a 2, 3 e 4 cassetti. Larghezze: 450, 600, 750 e 900 mm.

DRAWER UNITS in White, Magnolia or Pearl PVC finishing, 427 and 550 mm deep, available with 2, 3 and 4 drawers. Width: 450, 600, 750 and 900 mm.

PIEDINO inferiore in alluminio pressofuso con vite di regolazione da 0 mm. a 20 mm.

LOWER FOOT made of die-cast aluminium with adjusting screw from 0 to 20 mm.

PIEDINI h. 30 e 90 mm. o RUOTE h. 90 mm. per cassettiere
FEET h. 30 and 90 mm.
or WHEELS h. 90 mm. for drawer units.



ART. 110E - Raso Muro - MDF levigato e rivestito con carta da parati (a carico del cliente)
Flush-to-wall door - Smoot MDF covered with wallpaper (not supplied)



ART. 110E - Raso Muro - MDF con fondo bianco e pittura a tempera (a carico del cliente)
Flush-to-wall door - White base MDF with tempera paint (not supplied)



ART. 110E - Raso Muro - Laccato shine Bianco
Flush-to-wall door - Shine White lacquered



ART. 713E - Raso Muro - Rovere Moka
Flush-to-wall door - Moka Oak



ART. 120E - Raso Muro - Stampa digitale personalizzata su fondo bianco
Flush-to-wall door - Custom digital printing on white base



ART. 713E - Raso Muro - Rovere Tabacco
Flush-to-wall door - Tabacco Oak



ART. 711E - Raso Muro - Rovere Ghiaccio
Flush-to-wall door - Ghiaccio Oak

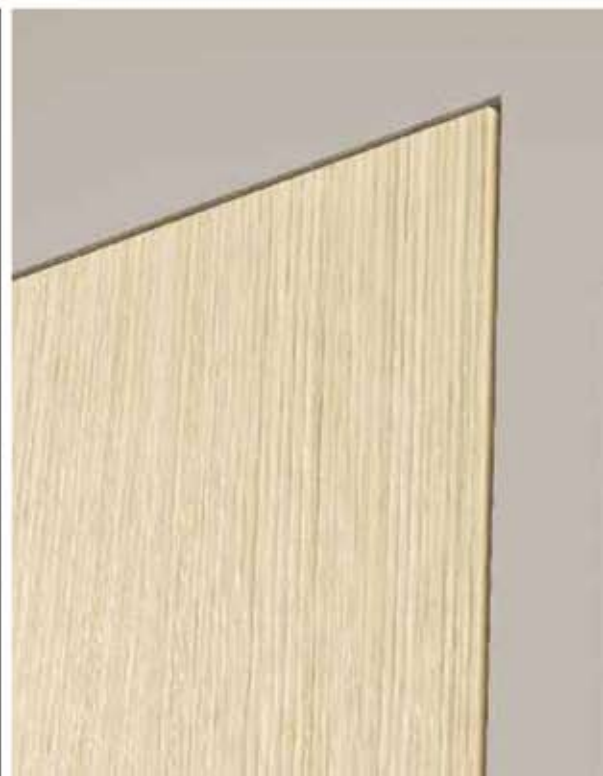

ART. 81G - Rovere Ghiaccio - Stipite S90
Ghiaccio Oak - Door Post S90

ART. 88G - Rovere Corda - Stipite S90
Corda Oak - Door Post S90

12

ITALIAN STYLE BY GIUGIARO DESIGN

Progettazione sofisticata
e ricerca contemporanea
di nuovi orizzonti espressivi.

Giugiaro Design fa capo al gruppo Italdesign-Giugiaro con sede a Moncalieri (Torino) dove risiedono le quattro aree funzionali interdipendenti dell'azienda: l'ufficio marketing e commerciale, il design center, il reparto ingegneria e la modelliera Giugiaro Design, per numero di addetti, competenza e operatività sul mercato internazionale, completezza e qualità dei servizi, è considerata una delle aziende leader a livello mondiale nel settore dell'industrial design. L'azienda è stata fondata dall'attuale Presidente, Giorgetto Giugiaro, nel 1981 e da allora ha accumulato una serie di competenze in molteplici settori dal product all'architettura, collaborando con aziende nazionali ed internazionali: Aermec, Alenia Aeronautica, Ansaldo Breda, Bburago, Beretta, Bridgestone, Ferrero, Fiat Engineering, Fiera di Milano, Studio Foster and Partners, JVC, Merloni, Nikon, Piaggio, Richard Ginori, Japan Science and Technology Corporation, Seiko, Sanpellegrino, Telecom, Trenitalia, Vredestein e molti altri. Oltre alla sede di Torino, Giugiaro Design è rappresentata con uffici in Francia, Spagna, Cina e Giappone.



ART. 87G - Frassino spazzolato Avorio - Stipite S90
Ivory brushed Ash-Tree - Door Post S90

ART. 83G - Rovere Ghiaccio - Stipite S90
Ghiaccio Oak - Door Post S90

ART. 87G - Rovere Tabacco - Stipite S90
Tabacco Oak - Door Post S90

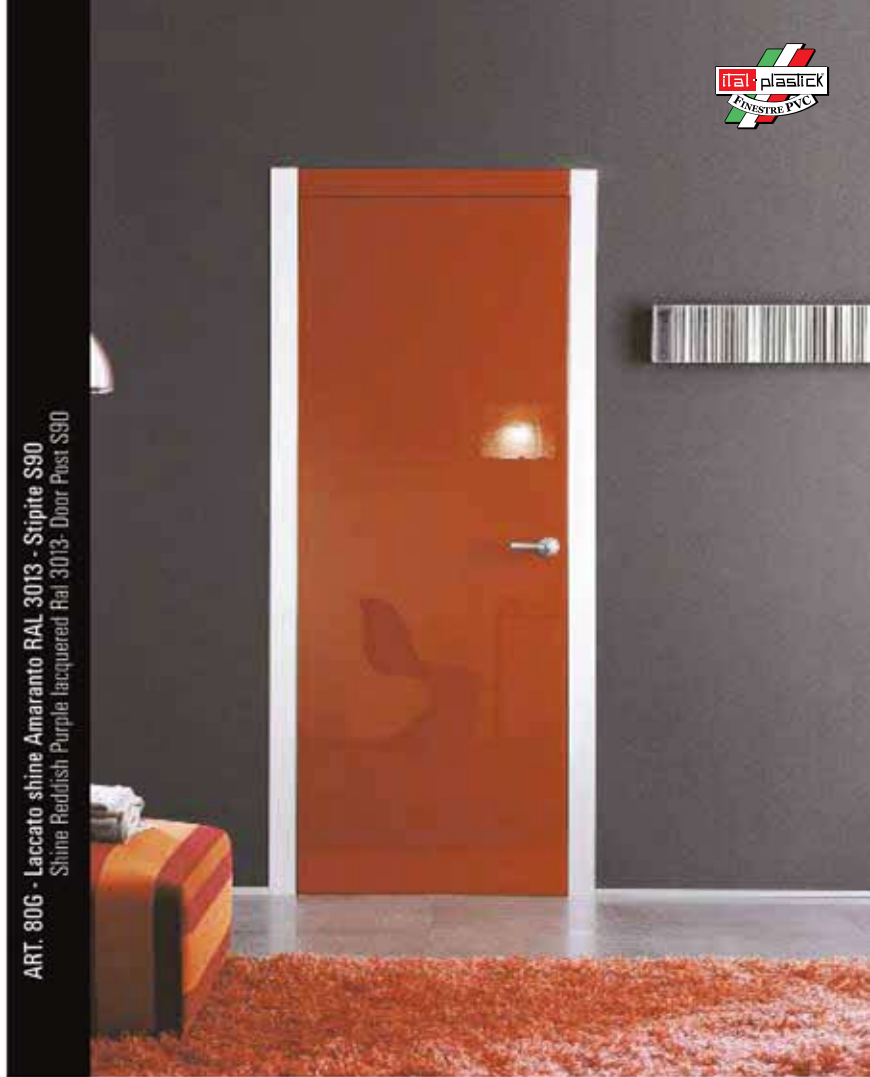

ART. 87G - Frassino spazzolato Giallo Curry - Stipite S90
Curry Yellow brushed Ash-Tree - Door Post S90



ART. 80G - Laccato shine Amaranzo RAL 3013 - Stipite S90
Shine Reddish Purple lacquered Ral 3013- Door Post S90

Sophisticated design,
contemporary research
for new expressive horizons.



Giugiaro Design belongs to the Italdesign-Giugiaro group, with headquarters in Moncalieri (Turin), where the four interdependent functional departments are also based, i.e. the marketing and sales department, the design centre, the engineering department and the modelling department. Because of the number of its employees, skills, international presence and range of complete and quality services, Giugiaro Design is considered one of the leading companies operating in the industrial design market segment. The company was established by its current CEO, Giorgetto Giugiaro, in 1981. Since its establishment it has been working in many markets, ranging from products to architecture, cooperating with Italian as well as international companies, including Aermac, Alenia Aeronautica, Ansaldo Breda, Bburago, Beretta, Bridgestone, Ferrero, Fiat Engineering, Fiera di Milano, Studio Foster and Partners, JVC, Merloni, Nikon, Piaggio, Richard Ginori, Japan Science and Technology Corporation, Seiko, Sanpellegrino, Telecom, Trenitalia, Vredestein and many more. In addition to the Turin headquarters, Giugiaro Design has offices in France, Spain, China and Japan.



ART. 80G - Laccato shine Avorio RAL 1013 - Stipite S90
Shine Ivory lacquered RAL 1013 - Door Post S90



ART. 90G - Rovere Miele - Stipite S90 - Vetro 91
Miele Oak - Door Post S90 - Glass 91



ART. 80G - Laccato shine Bianco - Stipite S90
Shine White lacquered - Door Post S90



ART. 104A - Stampa digitale su fondo Bianco - Stipite S40
Digital printing on White base - Door Post S40

ART. 120A - Stampa digitale personalizzata su fondo Bianco - Stipite S40
Customer digital printing on White base - Door Post S40



RAIMONDO SANDRI

La creatività sperimentale.

Nato nel 1966, opera nel settore del design dedicandosi a diverse forme espressive. Collabora con molte delle più importanti aziende italiane ed estere, (India, Grecia, Germania, Spagna) come ART director e designer. La continua ricerca personale lo porta a spostarsi trasversalmente tra discipline sperimentando nuovi linguaggi estetici. La sua attività si sviluppa in diverse aree tra graphic ed interior design. Ha disegnato bagni, mobili e complementi d'arredo, tappeti, tessuti, accessori per la moda, stationery, numerosi spazi espositivi e commerciali. Nel 2002 ha ricevuto il riconoscimento del premio internazionale "Best Plastic Award" per il design di una collezione di oggetti per la casa, dal 2004 è direttore artistico di Wissenbach Italia. Molti suoi progetti sono pubblicati da alcune importanti riviste del settore (Domus, Interni, Gap Casa, Elle Decor, Ottagono). Recentemente la Casa Editrice Red Publishing gli ha dedicato un volume monografico sulla creatività sperimentale.

Alcune collaborazioni:

Aprilia
Ducati
Gemini Yachts
Henry Cotton's
Converse All Star
Wissenbach
Zafferano

Du Pont De Nemur
Tim
Alcatel
MRB Group
Mandarina Duck
Inside
Red Wall



ART. 101A - Stampa digitale su fondo Bianco - Stipite S40
Digital printing on White base - Door Post S40

ART. 113A - Stampa digitale su fondo Bianco - Stipite S40
Digital printing on White base - Door Post S40



ART. 102A - Stampa digitale su fondo Bianco - Stipite S40
Digital printing on White base - Door Post S40





ART. 160Z - Incisione al laser su laccato Bianco - Stipite S40
Laser engraving on White lacquered - Door Post S40

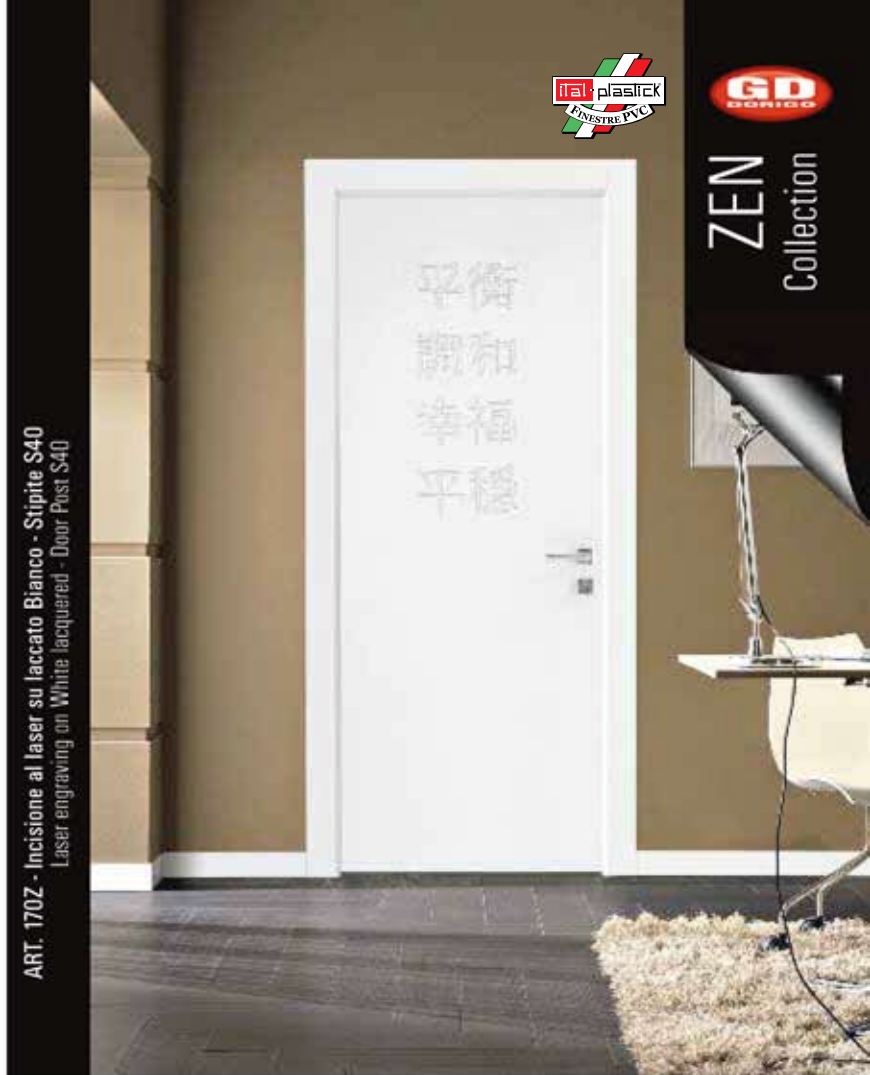

ART. 170Z - Incisione al laser su laccato Bianco - Stipite S40
Laser engraving on White lacquered - Door Post S40

The experimental creativity.

Born in 1966, he works in the design field devoting himself to various expressive kind. He cooperates as ART Director and designer with many of the most important Italian and foreign companies (India, Greece, Germany, Spain). His constant personal pursuit goes crosswire through different fields experiencing new aesthetic languages. His activity develops in different fields between graphic and interior design. He designed bathrooms, furniture and furniture equipments, carpets, fabrics, fashion accessories, stationery, many showrooms and commercial stores. In 2002 he received the international "Best Plastic Award" for the design of an houseware collection, since 2004 he has become Wisenbach Italia ART Director. Many of his projects have been published by important trade magazines (Domus, Interni, Gap Casa, Elle Décor, Dittagone). Lately the Red Publishing House dedicated to him a monographic volume on experimental creativity.

Some cooperations:

Aprilia
Ducati
Gemini Yachts
Henry Cotton's
Converse All Star
Wissenbach
Zafferano

Du Pont De Nemur
Tim
Alcatel
MRB Group
Mandarina Duck
Inside
Red Wall



ART. 156Z - Incisione al laser su laccato Bianco - Stipite S40
Laser engraving on White lacquered - Door Post S40



ART. 150Z - Incisione al laser su laccato Bianco - Stipite S40
Laser engraving on White lacquered - Door Post S40



ART. 165Z - Incisione al laser su laccato Bianco - Stipite S40
Laser engraving on White lacquered - Door Post S40



ART. 65D - Frassino Natural Poro Bianco - Vetro Rosso - Stipite S40
White Ash-Tree Natural Poro - Red glass - Door Post S40



ART. 62D - Rovere Corda - Stipite S40
Corda Oak - Door Post S40

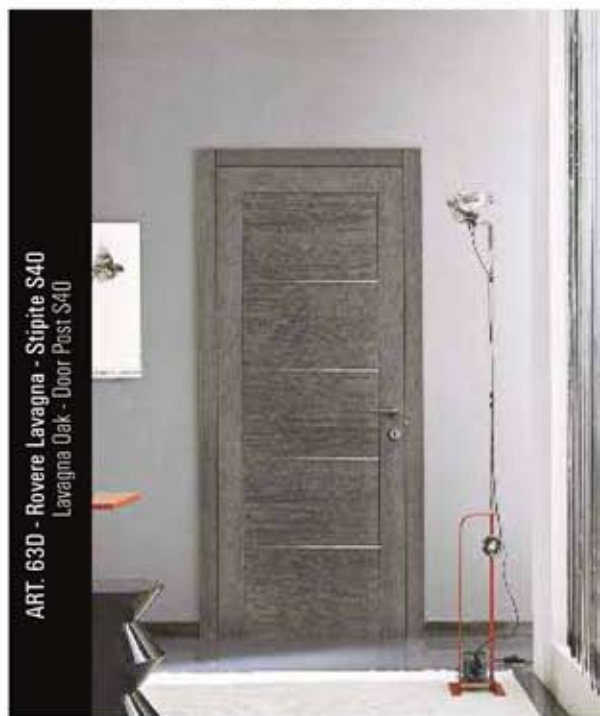

ART. 63D - Rovere Lavagna - Stipite S40
Lavagna Oak - Door Post S40



ART. 65D - Frassino Natural Poro Avorio - Stipite S40 - Vetro Marrone
Ivory Ash-Tree Natural Poro - Door Post S40 - Brown glass



ART. 65D - Rovere Moka - Stipite S40 - Vetro Bianco
Moka Oak - Door Post S40 - White glass



ART. 65D - Rovere Ghiaccio - Stipite S40 - Vetro Nero
Ghiaccio Oak - Door Post S40 - Black glass



ART. 61D - Rovere Tabacco - Stipite S40
Tabacco Oak - Door Post S40



ART. 60D - Laccato Bianco e Shine Bianco - Stipite S40
White lacquered and Shine White - Door Post S40

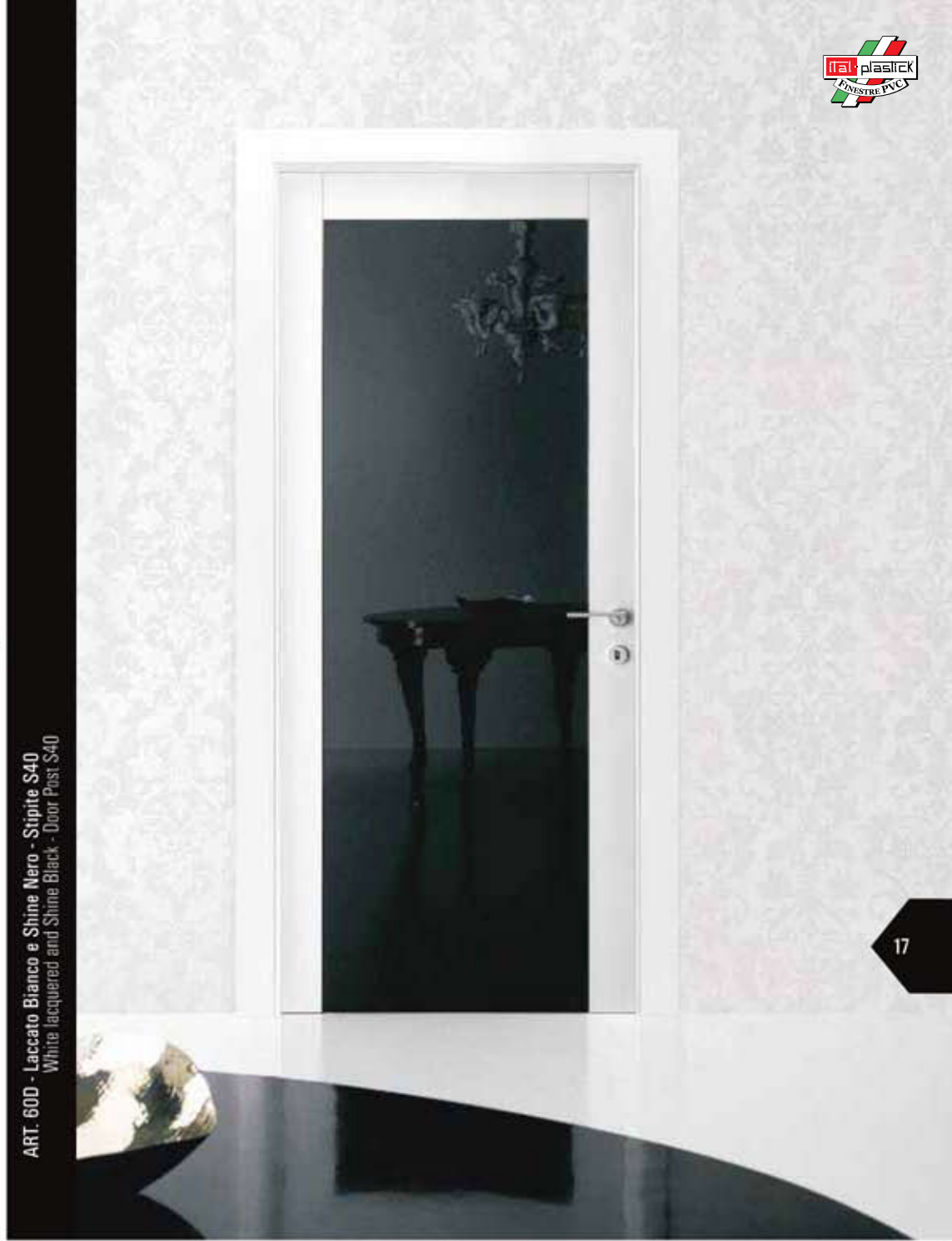

ART. 60D - Laccato Bianco e Shine Nero - Stipite S40
White lacquered and Shine Black - Door Post S40



ART. 62D - Laccato Bianco - Stipite S40
White lacquered - Door Post S40



ART. 60D - Laccato Avorio RAL 1013 - Stipite S40
Ivory lacquered RAL 1013 - Door Post S40



ART. 70D - Laccato Grigio RAL 7026 - Stipite S40 - Vetro 82
Grey lacquered RAL 7026 - Door Post S40 - Glass 82



ART. 430K - Rovere Miele - Stipite S40
Miele Oak - Door Post S40

ART. 795K - Rovere Lavagna - Stipite S40
Lavagna Oak - Door Post S40

ART. 791K - Rovere Ghiaccio - Stipite S40
Ghiaccio Oak - Door Post S40



ART. 310K - Rovere Moka - Stipite S40
Moka Oak - Door Post S40



ART. 731K - Rovere Ghiaccio - Stipite S40
Ghiaccio Oak - Door Post S40



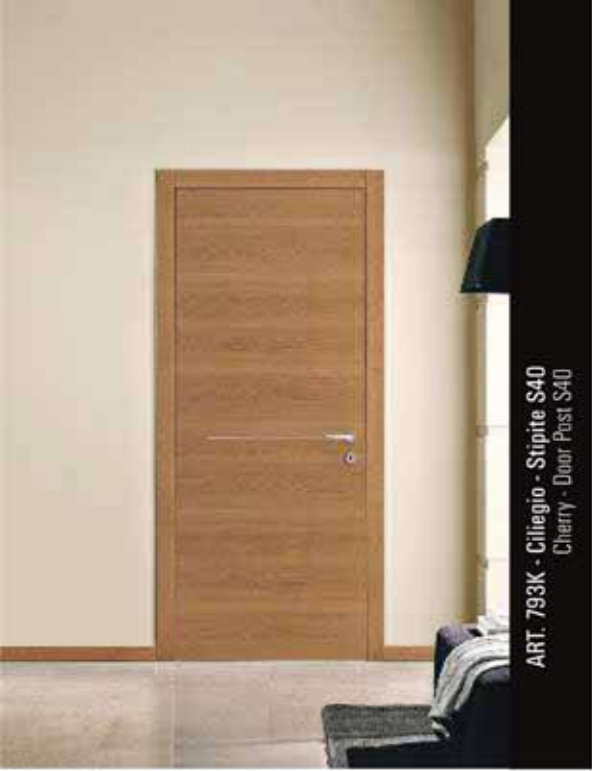

ART. 793K - Ciliegio - Stipite S40
Cherry - Door Post S40



ART. 730K - Rovere Tabacco - Stipite S40
Tabacco Oak - Door Post S40

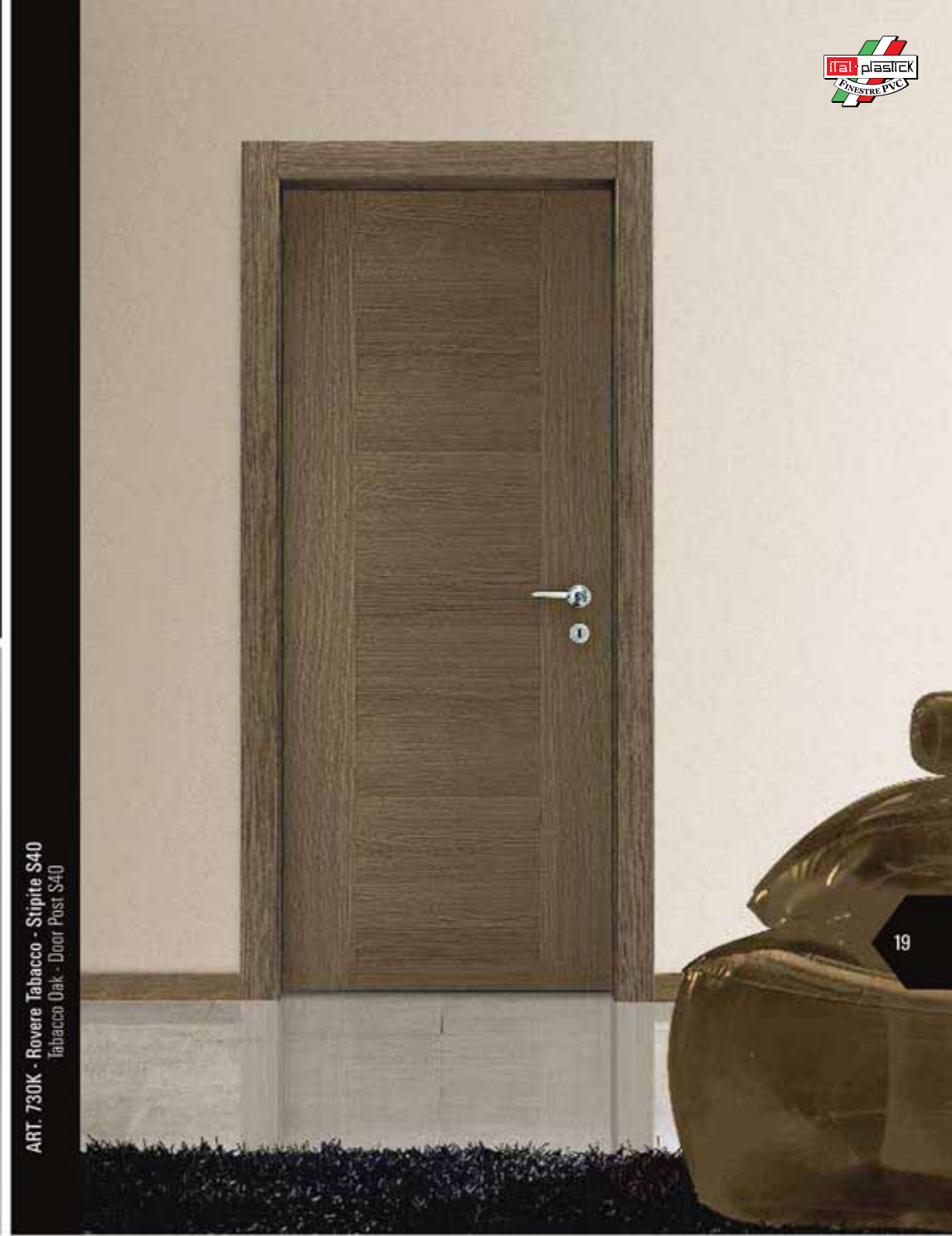

ART. 711K - Rovere Corda - Stipite S40
Corda Oak - Door Post S40



ART. 713K - Frassino spazzolato Bianco - Stipite S40
White brushed Ash-Tree - Door Post S40

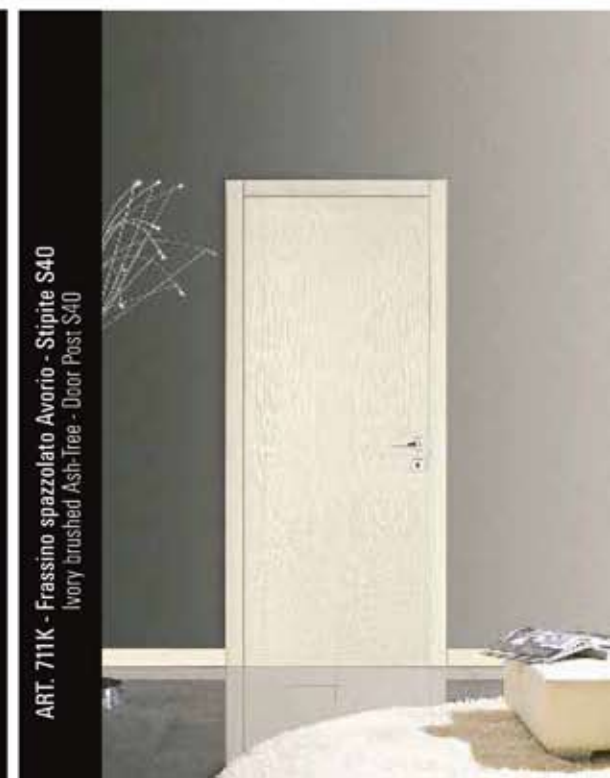

ART. 711K - Frassino spazzolato Avorio - Stipite S40
Ivory brushed Ash-Tree - Door Post S40



ART. - 396K - Laccato Avorio RAL 1013 - Stipite S40
Ivory lacquered - Door Post S40



ART. - 110K - Laccato Shine Marrone RAL 8014 - Stipite S40
Shine Brown lacquered RAL 8014 - Door Post S40



ART. - 80K - Laccato Bianco - Stipite S40 - Vetro 84
White lacquered - Door Post S40 - Glass 84



ART. - 110K - Laccato Bianco - Stipite S40
White lacquered - Door Post S40



ART. - 393K - Laccato Grigio RAL 7026 - Stipite S40
Grey lacquered RAL 7026 - Door Post S40



ART. - 372K - Laccato Bianco - Stipite S40
White lacquered - Door Post S40



ART. - 370K - Laccato Grigio Pastello RAL 7047 - Stipite S40
Light Grey lacquered RAL 7047 - Door Post S40

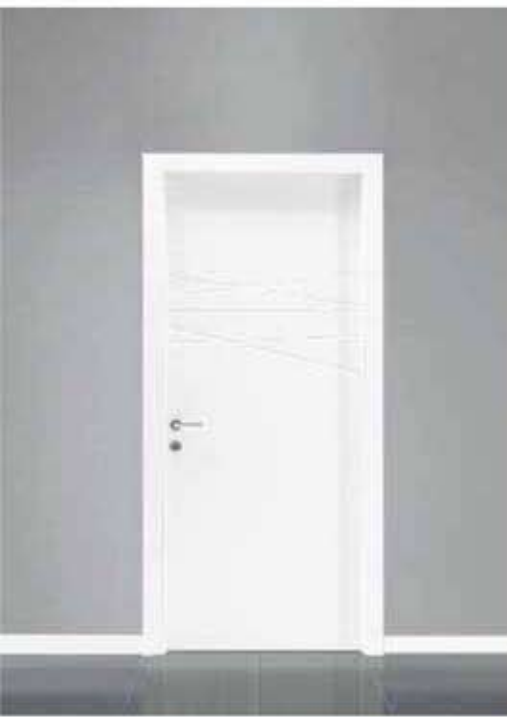

ART. - 362K - Laccato Bianco - Stipite S40
White Lacquered - Door Post S40



ART. - 368K - Laccato Bianco - Stipite S40
White Lacquered - Door Post S40



ART. - 364K - Laccato Grigio Pietra RAL 7030 - Door Post S40
Stone Grey lacquered RAL 7030 - Door Post S40



ART. - 366K - Laccato Bianco
White lacquered - Door Post S40



ART. - 360K - Laccato Bianco
White lacquered - Door Post S40



ART. 760i - Rovere Ghiaccio - Stipite C40
Ghiaccio Oak - Door Post C40



ART. 310i - Frassino - Stipite C50
Ash-Tree - Door Post C50



ART. 775i - Rovere Miele - Stipite C30
Miele Oak - Door Post C30



MAGIS - ART. 30 - Ciliegio - Stipite C30 - Vetro 71
Cherry - Door Post C30 - Glass 71



ART. 410i - Noce Nazionale - Stipite C50
Italian Walnut - Door Post C50



ART. 730i - Rovere Corda - Stipite C40
Corda Oak - Door Post C40



ART. 793i - Rovere Lavagna - Stipite C40
Lavagna Oak - Door Post C40



ART. 430i - Ciliegio - Stipite C50
Cherry - Door Post C50



ART. 795i - Rovere Moka - Stipite C40
Moka Oak - Door Post C40



ART. 790i - Ciliegio - Stipite C30
Cherry - Door Post C30



ART. 11 - Rovere Tabacco - Stipite C50
Tabacco Oak - Door Post C50



ART. 11 - Ciliegio - Stipite C30
Cherry - Door Post C30



ART. 11 - Rovere Ghiaccio - Stipite C40
Ghiaccio Oak - Door Post C40



ART. 11 - Frassino - Stipite C50
Ash-Tree - Door Post C50



ART. 11 - Noce Light - Stipite C60
Light Walnut - Door Post C60



ART. 13 - Frassino spazzolato Bianco - Stipite C40
White brushed Ash-Tree - Door Post C40



ART. 13 - Rovere Corda - Stipite C40
Corda Oak - Door Post C40



ART. 11 - Frassino spazzolato Avorio - Stipite C50
Ivory brushed Ash-Tree - Door Post C50



ART. 11 - Rovere Miele - Stipite C40
Miele Oak - Door Post C40

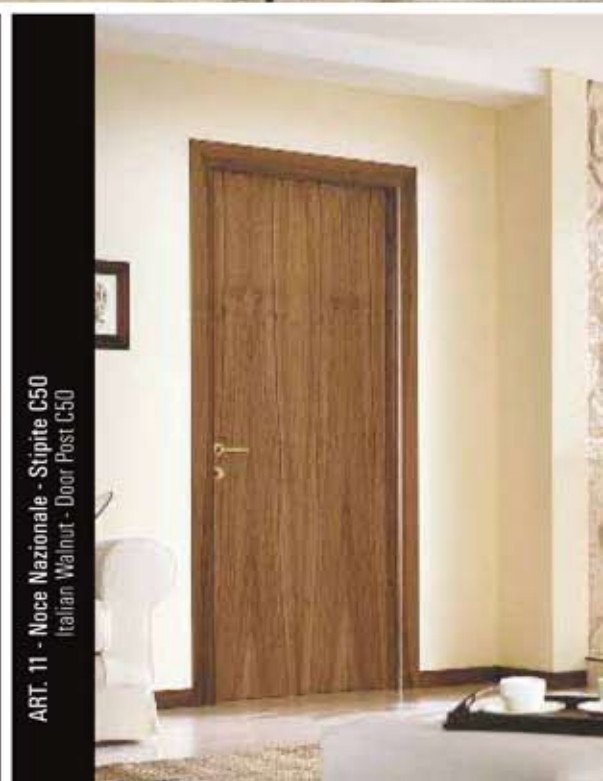

ART. 11 - Noce Nazionale - Stipite C50
Italian Walnut - Door Post C50



ART. 43 - Frassino Natural Poro Bianco - Stipite C50
White Ash-Tree Natural Poro - Door Post C50

ART. 68 - Frassino - Stipite C50
Ash-Tree - Door Post C50



ART. 43 - Ciliegio - Stipite C50
Cherry - Door Post C50



ART. 64 - Frassino Natural Poro Avorio - Stipite C50
Ivory Ash-Tree Natural Poro - Door Post C50



ART. 64 - Rovere Tabacco - Stipite C50
Tabacco Oak - Door Post C50





Art. 64 - Noce Nazionale - Stipite C50
Italian Walnut - Door Post C50



ART. 63 VIP - Rovere Miele - Stipite C50 - Vetro 78
Miele Oak - Door Post C50 - Glass 78



ART. 43 - Rovere Miele - Stipite C30
Miele Oak - z C30



ART. 68 - Laccato Avorio Anticato - Stipite C30 - Portale P945
Antique Ivory lacquered - Door Post C30 - Portal P945





ART. 61 - Rovere Miele - Stipite C30 - Portale P940
Miele Oak - Door Post C30 - Portal P940

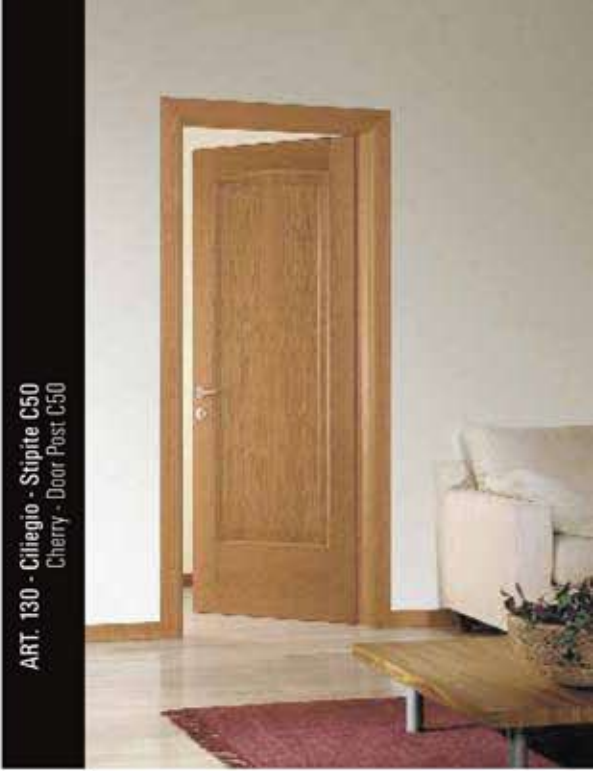

ART. 130 - Ciliegio - Stipite C50
Cherry - Door Post C50

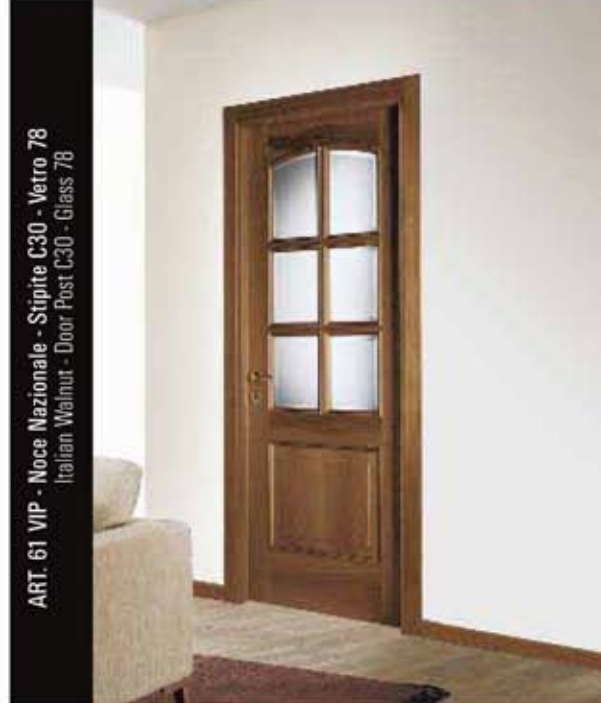

ART. 61 VIP - Noce Nazionale - Stipite C30 - Vetro 78
Italian Walnut - Door Post C30 - Glass 78



ART. 45 - Noce Nazionale - Stipite C50
Italian Walnut - Door Post C50

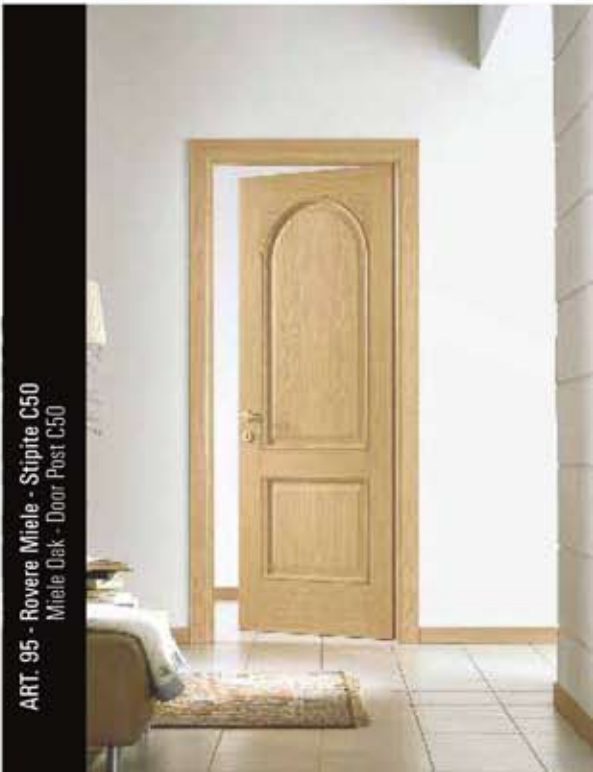
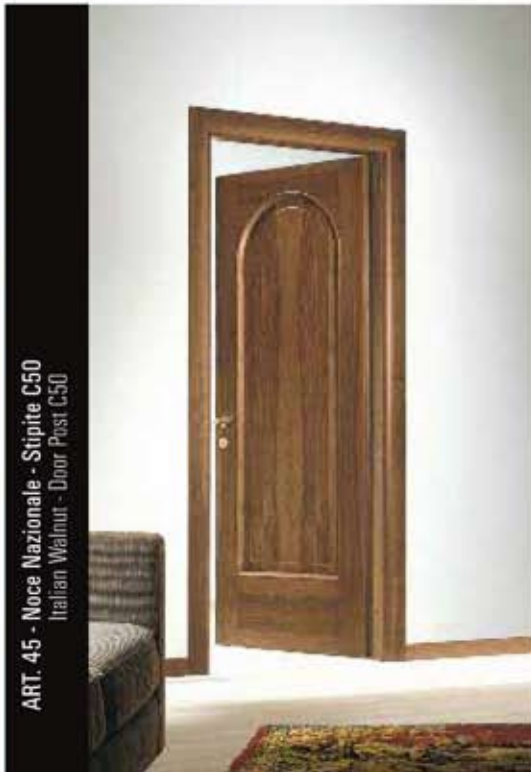

ART. 95 - Rovere Miele - Stipite C50
Miele Oak - Door Post C50



ART. 78 - Rovere Tabacco - Stipite C30 - Portale P950
Tabacco Oak - Door Post C30 - Portal P950



ART. 81 - Noce Nazionale - Stipite C50
Italian Walnut - Door Post C50



ART. 88 - Laccato Avorio Anticato - Stipite C30 - Portale P960
Antique Ivory Lacquered - Door Post C30 - Portal P960



ART. 85 - Laccato Avorio Anticato - Stipite C30 - Portale P960
Antique Ivory Lacquered - Door Post C30 - Portal P960





ART. 246 - Laccato Avorio RAL 1013 - Stipite C30
Ivory lacquered RAL 1013 - Door Post C30



ART. 230V - Laccato Bianco - Stipite C50 - Vetri 76
White lacquered - Door Post C50 - Glasses 76



ART. 230 - Laccato Bianco - Stipite C50
White lacquered - Door Post C50



ART. 250 - Blanc - Stipite C60
Blanc - Door Post C60



ART. 257V - Laccato Bianco - Stipite C50 - Vetro 72
White lacquered - Door Post C50 - Glass 72



ART. 280 - Laccato Avorio RAL 1013 - Stipite C40
Ivory lacquered RAL 1013 - Door Post C40



ART. 341 - Laccato Grigio Pietra RAL 7030 - Stipite C40
Stone Grey lacquered RAL 7030 - Door Post C40



ART. 241 - Laccato Bianco - Stipite C40
White lacquered - Door Post C40



ART. 361 - Laccato Beige RAL 1019 - Stipite C40
Beige lacquered RAL 1019 - Door Post C40



ART. 379 - Laccato Grigio Pastello RAL 7047 - Stipite C40
Light Grey lacquered RAL 7047 - Door Post C40



ART. 386 - Laccato Bianco - Stipite C40
White lacquered - Door Post C40



ART. 376 - Laccato Avorio RAL 1013 - Stipite C30
Ivory lacquered RAL 1013 - Door Post C30



ART. 396 - Laccato Bianco - Stipite C40
White lacquered - Door Post C40

MAGIS - ART. 31 - Laccato Arancione RAL 7010 - Stipite C50 - Vetro 75
Orange lacquered RAL 7010 - Door Post C50 - Glass 75



ART. 11 - ASIMMETRICO 1/3 + 2/3 - Laccato Grigio Pietra RAL 7030 - Stipite C30
Asymmetrical 1/3+2/3 - Stone Grey lacquered RAL 7030 - Door Post C30





ART. 11 - Laccato Avorio RAL 1013 - Stipite C50
Ivory lacquered RAL 1013 - Door Post C50

ART. 11 - Laccato Grigio RAL 7026 - Stipite C30 - Vetro 80
Grey lacquered RAL 7026 - Door Post C30 - Glass 80



ART. 11 - SIMMETRICO 1/2 + 1/2 - Laccato Blu RAL 5007 - Stipite C50
Symmetrical 1/2+1/2 - Blu lacquered RAL 5007 - Door Post C50



ART. 11 - Laccato Grigio Pastello RAL 7047 - Stipite C40
Light Grey lacquered RAL 7047 - Door Post C40



ART. 11 - Blanc - Stipite C60
Blanc - Door Post C60



MAGIS - ART. 35 - Soluzione "C" - Vetro 99 laccato Amarantho
"C" Solution - Glass 99 Reddish Purple lacquered

MAGIS - ART. 30 - Scorrevole a scomparsa - Ciliegio - Vetri 73
Sliding inside the wall - Cherry - Glasses 73



MAGIS - ART. 31 - Scorrevole in luce - Laccato Amarantho RAL 3010 - Vetri 77
Sliding superimposed - Reddish Purple lacquered - Glasses 77



MAGIS - ART. 35 - Soluzione "D" - Vetri 91
"D" Solution - Glasses 91



KING - ART. 713K - Soluzione "F" - Rovere Lavagna
"F" Solution - Lavagna Oak





DEGÒ - ART. 63D - Soluzione "D" - Rovere Moka
"D" Solution - Moka Oak



DEGÒ - ART. 61D - Scorrevole a scomparsa - Rovere Ghiaccio
Sliding inside the wall - Ghiaccio Oak



IMAGO - Art. 11 - Soluzione "B" - Rovere Corda
"B" Solution - Corda Oak

KING - ART. 713K - Soluzione "E" - Frassino Spazzolato Viola
"E" Solution - Violet brushed Ash-Tree



MAGIS - ART. 30 - Scorrevole in luce - Rovere Miele
Sliding superimposed - Miele Oak - Glasses 71/80



ESSENZE WOOD VENEERS

MDF
Levigato
Smooth

Disponibile solo
per ETEREA Collection
Available only for
ETEREA Collection



MDF
Fondo bianco
White Base

Disponibile solo
per ETEREA Collection
Available only for
ETEREA Collection



FRASSINO
ASH-TREE



ROVERE
CORDA
CORDA
OAK



ROVERE
MIELE
MIELE
OAK



ROVERE
GHIACCIO
ICY OAK



STIPITI DOOR POST



C30
Imago
Lego
Effigies



C30
Venus (laccato/lacquered)



C40
Imago
Lego
Effigies



C40
Venus (laccato/lacquered)



C50
Imago
Lego
Effigies
Venus



C60
Noce Light
(rivestito legno/
wood veneered)



C60
Blanc (laccato/lacquered)



S40
Degò
King (rivestito legno/
wood veneered)



S40
Art
Zen
Degò (laccato/lacquered)
Decor



S90 80x21
IKI



S90 115x21
IKI

ROVERE MOKA MOKA OAK	ROVERE TABACCO TOBACCO OAK	ROVERE LAVAGNA LAVAGNA OAK	NOCE NAZIONALE ITALIAN WALNUT	CILIEGIO CHERRY	NOCE LIGHTE LIGHT WALNUT	FRASSINO NATURAL PORO BIANCO	FRASSINO NATURAL PORO AVORIO
						WHITE NATURAL PORO ASH-TREE	IVORY NATURAL PORO ASH-TREE



FRASSINO
SPAZZOLATO
BRUSHED
ASH-TREE



COLORI
COLOURS

Per tutti i frassini spazzolati il grado di spazzolatura ed i riferimenti RAL sono puramente indicativi e non sono confrontabili essendo realizzati su impiallacciatura di legno che per natura presenta colorazioni e venature variabili.
For all the brushed ash-trees the degree of the brush and finishings the RAL colours references are purely indicative and they are not comparable being realized on wood veneer that may have by nature different grains and colours.



BIANCO
WHITE



AVORIO
IVORY



COLORI
COLOURS

Finiture laccate,
disponibili
in tutti i colori
della Mazzotta RAL.

Laquered finish,
available in all RAL
colors from
the standard selector.

LACCATI
OPACHI O
LUCIDI/SHINE
MATT OR
GLOSSY/SHINE
LACQUERED
COLOURS

TRASPARENZE
CHE
ALLARGANO
GLI
AMBIENTI.

38

TRASPARENCIES
THAT
WIDEN
THE
AMBIENCES.



Mod. 57
Vetro Grigio/Grey Glass



Mod. 58
Specchio/Mirror



Mod. 59
Vetro Bronzo/Bronze Glass



Mod. 60



Mod. 61



Mod. 68



Mod. 69



Mod. 71



Mod. 72



Mod. 73



Mod. 81



Mod. 82



Mod. 84



Mod. 85



Mod. 86



Mod. 62



Mod. 63



Mod. 64



Mod. 65



Mod. 66



Mod. 67



Mod. 75



Mod. 76



Mod. 77



Mod. 78
Vetro Bisollato/Bevellid Glass



Mod. 79
Vetro Trasparente/Clear Glass



Mod. 80
Vetro Satinato/Satinated Glass

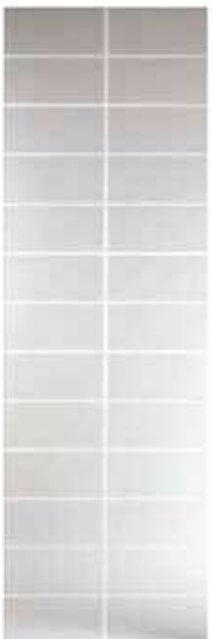

Mod. 90



Mod. 91



Mod. 92



Mod. 93



Mod. 94



Mod. 96

FINITURE FINISHING

Le tinte e i colori sono
puramente indicativi.
The colours are given
as an indication.

ALFA

Simil Noce chiaro
Similar Light Walnut



CRONO

Simil Larice
Similar Larch



EPSILON

Simil Wengè
Similar Wengè



GAMMA

Simil Rovere sbiancato
Similar Bleached Oak



SIGMA

Simil Noce Canaletto
Similar Canaletto Walnut



JOTA

Simil Frassino bianco
Similar White Ash-Tree



OMEGA

Bianco
White



OMEGA SPAZZOLATO



SINCRO

Simil Frassino
Similar Ash-Tree



Tau

Avorio
Ivory



TAU VENATO



ZETA

Simil Noce Nazionale
Similar Italian Walnut

STIPITI DOOR POST



R10

Alfa
Crono
Epsilon
Gamma
Jota
Omega
Sigma
Sincro
Tau
Zeta



R40

Alfa
Crono
Epsilon
Gamma
Jota
Omega
Sincro



R80

Alfa
Crono
Epsilon
Gamma
Jota
Omega
Sincro



DOOR^SPLANET è la rappresentazione più attuale della produzione di porte di arredo, frutto della fusione tra maestria artigiana e automazione industriale.

Nate su uno specifico bisogno evolutivo del mercato, l'intera gamma attinge agli stimoli e alle contaminazioni estetiche del mondo del mobile.

Caratteristica distintiva di questa gamma è la varietà dei rivestimenti che grazie ad una specifica soluzione tecnologica elaborata in GD DORIGO e battezzata **plantext** garantisce soluzioni che riproducono fedelmente le essenze del legno aggiungendo plus di maggiore resistenza superficiale alle abrasioni e ai graffi.

I rivestimenti **plantext** della GD DORIGO sono inoltre facili da pulire e mantengono una colorazione inalterabile e una superficie indistruttibile nel tempo.

plantext è la nuova frontiera che l'azienda ha deciso di superare per sviluppare nuovi prodotti d'arredo eccellenti dal punto di vista estetico e competitivi sotto il profilo economico.

Molto più di una soluzione tecnologica; una strategia di produzione e commercializzazione innovativa, al passo con i tempi e coerente con i bisogni del mercato globale.

DOOR^SPLANET is our latest representation of the production of doors furniture and exemplifies the result of fusing craftsmanship with industrial automation.

Born to answer specific developmental needs created by the market, the entire DoorsPlanet series draws from influences and aesthetics of the furniture.

The distinctive feature of this range(series) is the variety of finishing coatings created by a unique technological solution developed by GD DORIGO. **plantext** provides solutions that faithfully reproduce wood types, plus adds more surface resistance to abrasion and scratches.

The **plantext** GD DORIGO coatings are also easy to clean and maintain as their color and surface are unalterable and indestructible over time.

plantext is the company's answer to overcoming the new frontier, by developing new products both with excellence in aesthetics, and that are competitive economically.

Much more than a technological solution, this product strategy and marketing innovation keeps pace with the times and is consistent with the needs of the global market.



ART. P11 - Jota - Stipite R40
Jota - Door Post R40



ART. P13 - Gamma - Stipite R10
Gamma - Door Post R10



ART. P13 - Jota - Stipite R10
Jota - Door Post R10

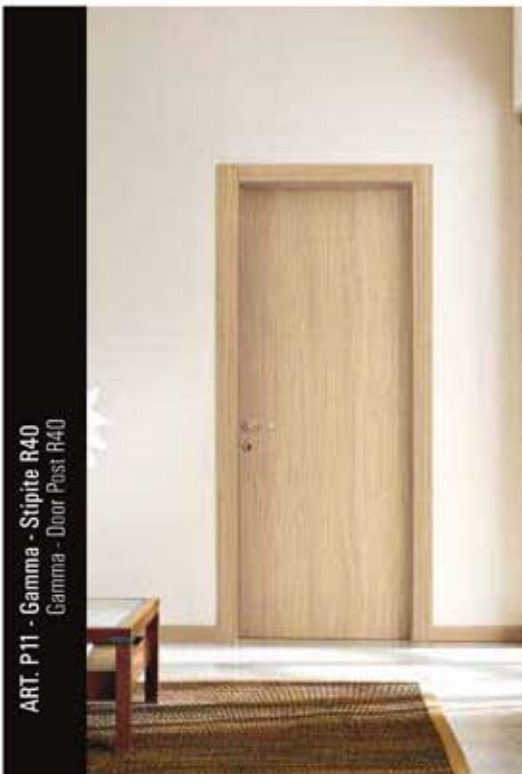

ART. P11 - Gamma - Stipite R40
Gamma - Door Post R40



ART. P11V - Gamma - Stipite R10 - Vetro 63
Gamma - Door Post R10 - Glass 63



ART. P11 - Sincro - Stipite R40
Sincro - Door Post R40



ART. P13 - Crono - Stipite R80
Crono - Door Post R80



ART. P11 - Epsilon - Stipite R10
Epsilon - Door Post R10



ART. P13 - Sincro - Stipite R80
Sincro - Door Post R80



ART. P11 - Crono - Stipite R10
Crono - Door Post R10



ART. P13 - Tau venato - Stipite R10
Venato Tau - Door Post R10



ART. P13 - Omega spazzolato - Stipite R80
Brushed Omega - Door Post R80



ART. P11 - Omega - Stipite R10
Omega - Door Post R10

Tau venato
Venato Tau

Omega spazzolato
Brushed Omega



ART. P11 - Tau - Stipite R10
Tau - Door Post R10



ART. P11 - Sigma - Stipite R10
Sigma - Door Post R10



ART. P13 - Alfa - Stipite R40
Alfa - Door Post R40



ART. P13 - Epsilon - Stipite R80
Epsilon - Door Post R80



ART. P11 - Zeta - Stipite R10
Zeta - Door Post R10

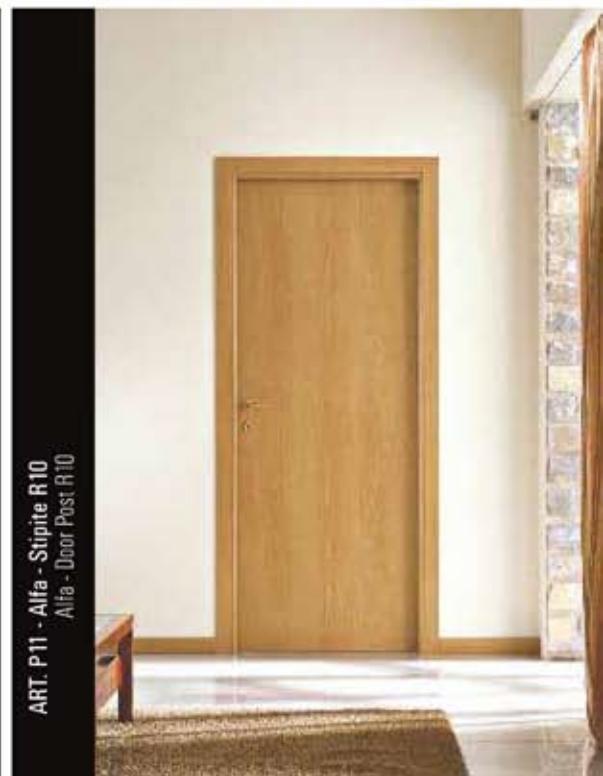

ART. P11 - Alfa - Stipite R10
Alfa - Door Post R10



46

ART. M110 - Crono - Stipite R80
Crono - Door Post R80

ART. M112 - Alfa - Stipite R10
Alfa - Door Post R10

ART. M112 - Omega - Stipite R10
Omega - Door Post R10



ART. M110 - Sigma - Stipite R10
Sigma - Door Post R10

ART. M110 - Epsilon - Stipite R40
Epsilon - Door Post R40



ART. M110 - Gamma - Stipite R10
Gamma - Door Post R10





ART. M112 - Gamma - Stipite R40
Gamma - Door Post R40



ART. M112 - Crono - Stipite R10
Crono - Door Post R10



ART. M114 - Sincro - Stipite R80
Sincro - Door Post R80



ART. M114 - Tau - Stipite R10
Tau - Door Post R10



ART. M114 - Alfa - Stipite R10
Alfa - Door Post R10



ART. M114 - Jota - Stipite R40
Jota - Door Post R40



ART. Z210 - Gamma - Stipite R40
Gamma - Door Post R40



ART. Z214 - Alfa - Stipite R40
Alfa - Door Post R40



ART. Z272 V - Gamma - Stipite R10 - Vetro 68
Gamma - Door Post R10 - Glass 68

ART. Z214 - Gamma - Stipite R80
Gamma - Door Post R80



ART. Z214 - Jota - Stipite R10
Jota - Door Post R10





Art. Z216 - Omega - Stipite R40
Omega - Door Post R40



Art. Z276 V - Jota - Stipite R80 - Vetro 80
Jota - Door Post R80 - Glass 80



ART. Z176 - Alfa - Stipite R40
Alfa - Door Post R40



ART. Z276 V - Gamma - Stipite R40 - Vetro Nero
Gamma - Door Post R40 - Black Glass



ART. - Z276 V - Omega - Stipite R80 - Vetro Rosso
Omega - Door Post R80 - Red Glass



ART. V320A - Jota - Stipite R80
Jota - Door Post R80



ART. V320E - Gamma - Stipite R40
Gamma - Door Post R40



ART. V320A - Sigma - Stipite R10
Sigma - Door Post R10

ART. V320A - Alfa - Stipite R10
Alfa - Door Post R10



ART. V320E - Omega - Stipite R80
Omega - Door Post R80





ART. V310 - Sigma - Stipite R10
Sigma - Door Post R10

ART. V350V - Omega - Stipite R10 - Vetro 62
Omega - Door Post R10 - Glass 62



ART. V310 - Alfa - Stipite R10
Alfa - Door Post R10



ART. V310 - Jota - Stipite R40
Jota - Door Post R40

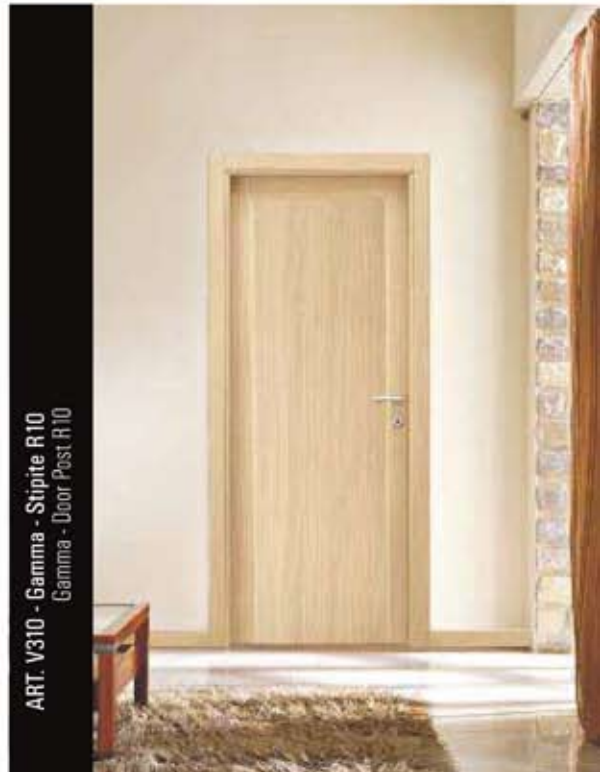

ART. V310 - Gamma - Stipite R10
Gamma - Door Post R10



ART. A41 - Gamma - Stipite R40
Gamma - Door Post R40



ART. A61 - Zeta - Stipite R10
Zeta - Door Post R10



ART. A41 - Epsilon - Stipite R80 - Specchio liscio
Epsilon - Door Post R80 - Flat panel

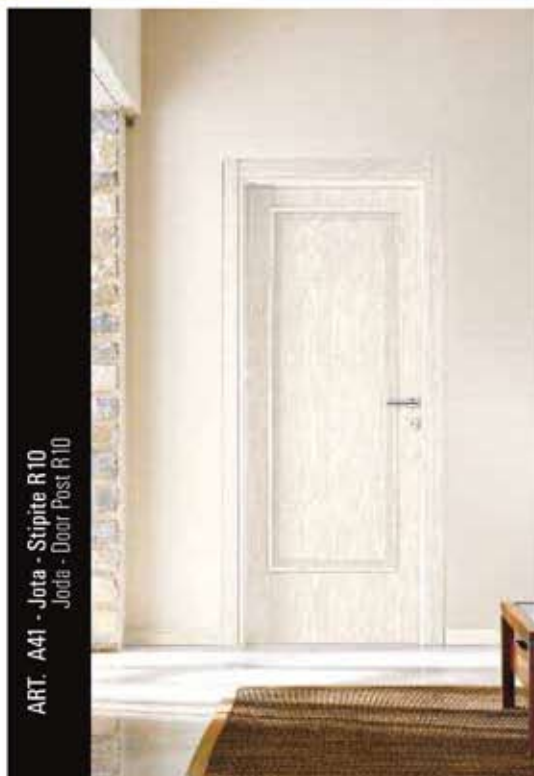

ART. A41 - Jota - Stipite R10
Jota - Door Post R10



ART. A41V - Omega - Stipite R40 - Vetro 61
Omega - Door Post R40 - Glass 61



ART. A61 V - Sigma - Stipite R10 - Vetro 67
Sigma - Door Post R10 - Glass 67

ART. A78 - Sincro - Stipite R80
Sincro - Door Post R80



ART. A61 - Alfa - Stipite R10
Alfa - Door Post R10



ART. A61 - Tau - Stipite R10
Tau - Door Post R10

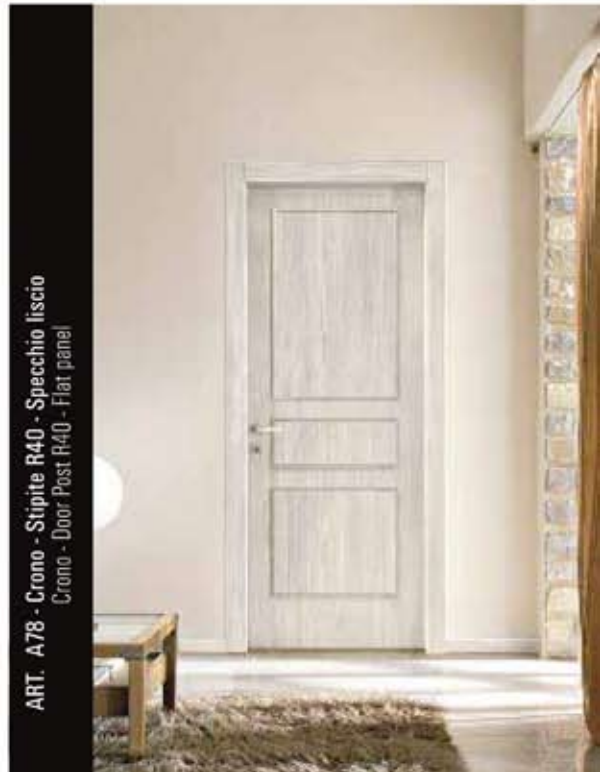

ART. A78 - Crono - Stipite R40 - Specchio liscio
Crono - Door Post R40 - Flat panel

NOTA GENERALE

Le fotografie dei prodotti illustrate nel catalogo ed i campioni in possesso del committente, hanno valore puramente indicativo e pubblicitario. Il committente non potrà fondare alcun reclamo su eventuali differenze tra la merce fornita e quanto risulta dal materiale dimostrativo in suo possesso. La GD Dorigo Spa, si riserva inoltre la facoltà di apportare ai propri prodotti, le migliorie di carattere tecnico e costruttivo che riterrà opportune.

NOTE

The photos of the products illustrated in this catalogue and the samples in possession of the buyer have only indicative and advertising value. The buyer can not found any claim on eventual differences between the supplied goods and the demonstrative samples in his/her possession. Moreover GD Dorigo Spa reserves the right to make technical, constructive or design changes at any time and without prior notice.

THE DOORS MADE IN ITALY ELEGANT AND INNOVATIVE, WHICH OPENS UP NEW SCENARIOS OF INTERIOR ARCHITECTURE.

A complete repertoire of doors for private and public buildings, dedicated to those seeking aesthetic content of prestige and quality. The signature GD Dorigo, the Italian industry that manages the high-tech care with the typical craft tradition.



GD DORIGO is one of the main Italian industries that is ever evolving excellent craftsmanship in advanced industrialization processes in the production of doors for interiors, and technological doors for the industry of professional buildings such as hospitals, hotels, schools and offices.

The heart of this Company is its values. Typically of Italian, it focused company growth and development while centering its attention on people as the key lever to deal with the continuing development of professional markets.

The GD DORIGO brand represents a company so in step with the times; an organization founded on the rationality of its production system and experience which is continually fueled by innovation stimuli.

In line with the most pronounced trends in the market, today, GD DORIGO also demonstrates a strong "green" culture, in the choice of raw materials and alternative energy solutions aimed at limiting the impact and industrial pollution. Each square meter of the Company exemplifies business decisions that take an evolutionary path to certify products are of a high functional and aesthetic level.

Special attention is always given to strategic design to capitalize on the manufacturing culture that as a "laboratory of Made in Italy" gives form to new ideas and stimulates constructive experiments. These turn our products into successes such as those developed with the contribution of creative and important designers such as Giugiaro.

Doors are at the heart GD DORIGO. Most importantly this is where each member puts his skills and his attention with a creative awareness that communicates and represents the entire value of the brand.

Value-added benefits accompany our products, including in all commercial and technical support to customers who are treated as friends by the Company and therefore have an exclusive reference to work from with safety and satisfaction.

Our products all have an Industrial Automation and Artisanry signature, starting from our company in Pieve di Soligo, which gradually expands not only throughout our country, but in all those emerging areas in the world who aspire to absorb Italian culture and values and aesthetics of the image told through our doors.





CAMBIA IL TUO SPAZIO

DISEGNA LO STILE
DI CASA TUA

RIVENDITORE



ITALIAN DOORS STORY

www.gd-dorigo.com